

EXISTING CONCRETE
(10MPa CONCRETE IF NEW INSTALLATION)

BOLLARDS CAN BE BOLTED DOWN USING JMB SURFACE MOUNT INSTALLATION KIT. PRODUCT REF : MK203

THE INSTALLATION KIT CONTAINS 4 UNITS OF 16 x 65mm DYNA BOLT CEMENT ANCHORS

GUIDELINES FOR FITTING ANCHOR BOLTS:
(Manufacturers instruction and local regulations should always take precedent over these installation guidelines)

1. DRILL 4 x $\varnothing 16$ HOLES 65mm DEEP AT 120mm CENTRES
2. TIP: (Use the base unit as a drilling template)
3. CLEAN DUST OUT THE HOLES
4. POSITION THE BASE AND GENTLY TAP THE ANCHOR BOLTS THROUGH THE BASE HOLES USING A SOFT HAMMER
5. TIGHTEN THE NUTS IN A DIAGONAL PATTERN UNTILL ALL ARE FULLY TENSIONED

NOTE 1:

SIMILAR CAPACITY ANCHOR BOLTS THAT USE AN M12 OR LARGER THREAD CAN BE SUBSTITUTED

NOTE 2:

IF CONCRETEING A NEW FOOTING, A FOOTING SIZE OF 400mm X 400mm X 400mm DEEP USING 10MPa IS ADVISED IF NO OVERRIDING LOCAL REGULATIONS ARE APPLICABLE

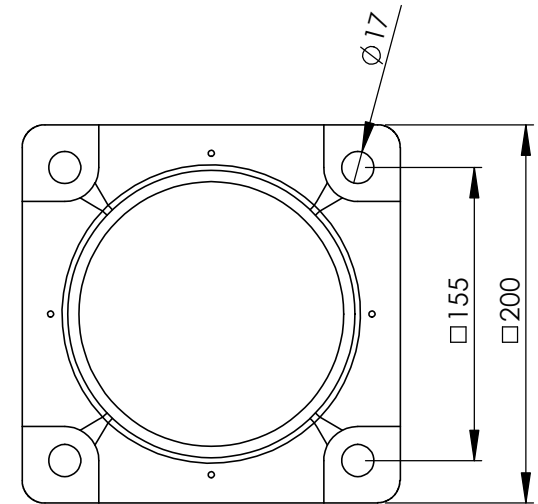

PLAN OF HOLE PATTERN

**INFORMATION APPLICABLE TO:
LRB AND HRB SPRING RETURN BOLLARDS**

SCALE	NTS
CHECKED	ICB
LAST UPDATE	4/02/2016
DRAWN	Ian Brodie
DATE	23/01/2012

 ALL DIMENSIONS IN MILLIMETERS	QUANTITY	DO NOT SCALE IF IN DOUBT ASK
MATERIAL	NA	
FINISH	NA	
DESCRIPTION	SPRING RETURN BOLLARDS JMB TECHNICAL INFORMATION SHEET 13 SURFACE MOUNT INSTALLATION INSTRUCTIONS	

JMB MANUFACTURING PTY LTD 24 BRIGID BOULEVARD AUSTINE HEIGHTS QLD AUSTRALIA 4300 PH. 07 3814 7882 FAX. 07 3814 7884		
ACAD FILE NAME	Technical Information 27-06-2014	SH. 11
Part:		OF 13

SOCKET MOUNT ADAPTOR KIT - PRODUCT REF: SA410A

CONTAINS:

- 4 X M16 x 25 HEX BOLTS (Galv)
- 4 X M16 FLAT WASHERS Galv)
- 1 X SA410 187mm SOCKET MOUNT ADAPTOR
- 1 x WE001 LOCKING WEDGE (not required for direct cement in)

SOCKET MOUNT ADAPTORS CAN BE INSTALLED DIRECTLY INTO A CONCRETE FOOTING. IF DOING THIS IT IS RECOMMENDED TO FLATTEN THE END OF THE TUBE A SMALL AMOUNT WITH A HAMMER TO INHIBIT ANY CHANCE OF ROTATION

INSTALLING SOCKET MOUNT ADAPTOR:
please refer to standard installation specifications produced by road authorities in your region as soil conditions and specifications may be different. This information is intended as a guide and any local authority specifications should will take precedence.

FOOTING:
If installing a new footing we recommend a minimum of 400mm square by 500mm deep. Allow at least 50mm beneath the gorund socket.

GUIDLINES FOR INSTALLING:
(Local regulations should always take precedent over these installation guidelines)

PRODUCT REF : SA410A

1. ORIENTATE AND SET SOCKET MOUNT ADAPTOR INTO FOOTING
2. CONCRETE ADAPTOR IN PLACE USING MIN 10MPa CONCRETE
3. LEAVE CONCRETE TO SET BEFORE FITTING THE SPRING RETURN BOLLARD
4. BOLT THE SPRING RETURN BOLLARD TO THE SOCKET MOUNT ADAPTOR AND TIGHTEN DIAGONALLY

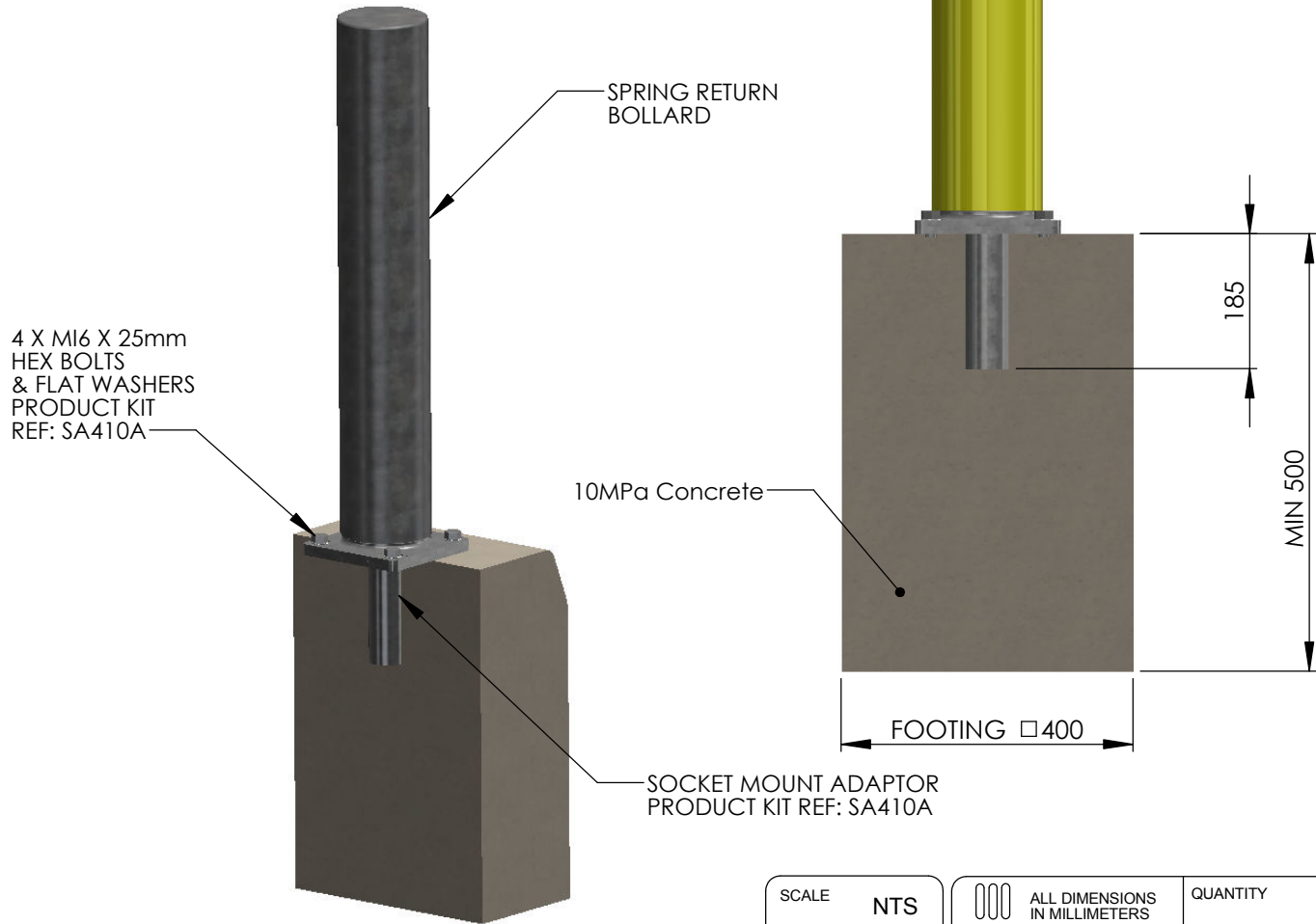

**INFORMATION APPLICABLE TO:
LRB AND HRB SPRING RETURN BOLLARDS**

SCALE	NTS
CHECKED	ICB
LAST UPDATE	4/02/2016
DRAWN	Ian Brodie
DATE	23/01/2012

ALL DIMENSIONS IN MILLIMETERS	QUANTITY	DO NOT SCALE IF IN DOUBT ASK
	MATERIAL	NA
	FINISH	NA
DESCRIPTION		
SPRING RETURN BOLLARD JMB TECHNICAL INFORMATION SHEET 14 SOCKET MOUNT ADAPTOR - DIRECTLY CONCRETE INTO FOOTING INSTALLATION GUIDELINES		

JMB MANUFACTURING PTY LTD 24 BRIGID BOULEVARD AUSTINE HEIGHTS QLD AUSTRALIA 4300 PH. 07 3814 7882 FAX. 07 3814 7884		
ACAD FILE NAME	SH. 12	
Technical Information 27-06-2014		
Part:	OF 13	

SPRING RETURN BOLLARD

- LRB001 GREY FINISH AS SHOWN
- LRB002 SAFETY YELLOW FINISH
- LRB003 SAFETY YELLOW FINISH 1.3m HIGH

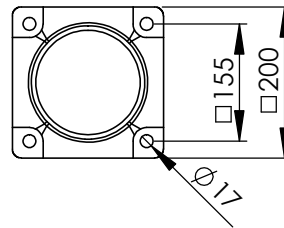
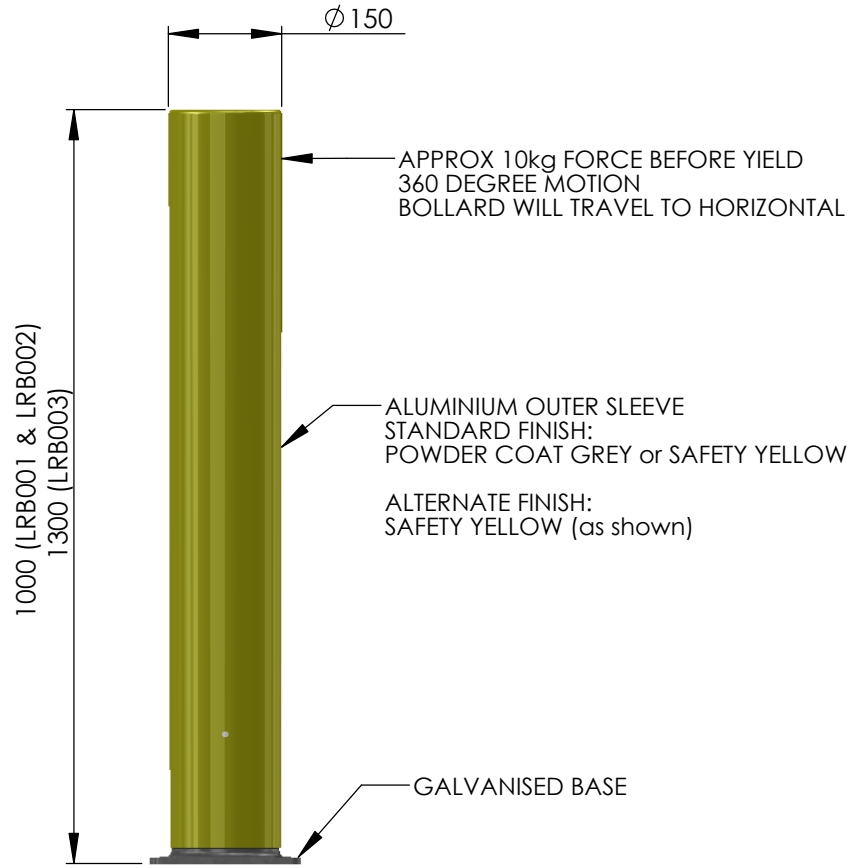

SCALE	NTS	ALL DIMENSIONS IN MILLIMETERS	QUANTITY	DO NOT SCALE IF IN DOUBT ASK
CHECKED	ICB		MATERIAL	NA
LAST UPDATE	4/02/2016	FINISH	NA	
DRAWN	Ian Brodie	DESCRIPTION	SPRING RETURN BOLLARDS JMB TECHNICAL INFORMATION SHEET 15 GENERAL INFORMATION	
DATE	23/01/2012			

JMB MANUFACTURING PTY LTD 24 BRIGID BOULEVARD AUSTINE HEIGHTS QLD AUSTRALIA 4300 PH. 07 3814 7882 FAX. 07 3814 7884		
ACAD FILE NAME	SH. 13	
Technical Information 27-06-2014	OF 13	
Part:		

DIFFERENT HEIGHTS AND FINISHES CAN BE SUPPLIED BY SPECIAL ORDER